

EE 435

Lecture 19

- Op Amp Simulation Strategies
- Other methods of gain enhancement

Review from last lecture

Basic Two-Stage Op Amp

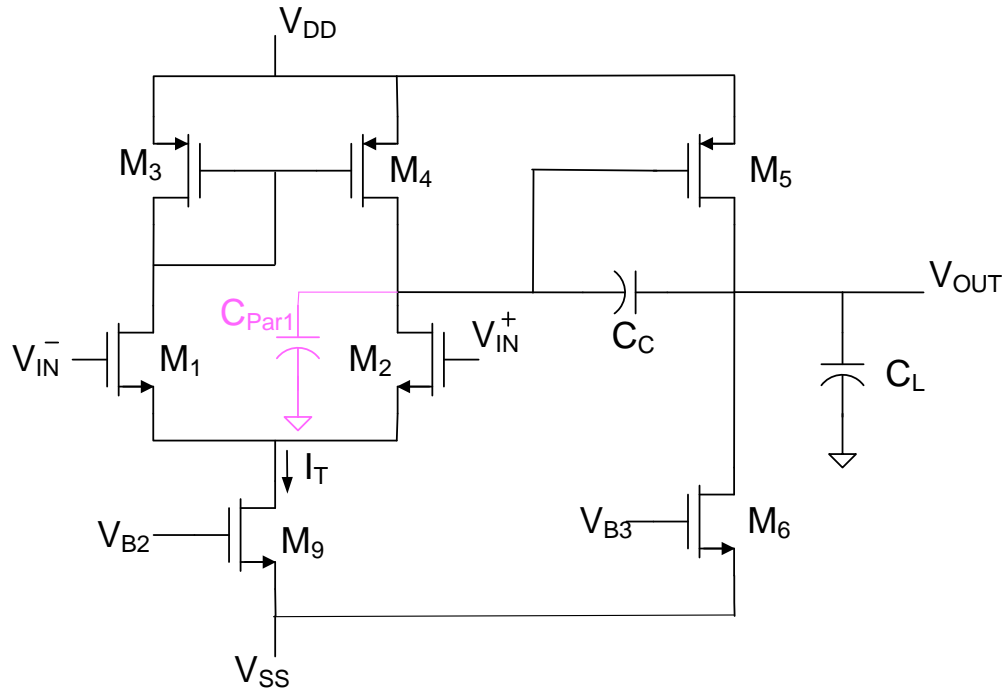

$$A_{FB}(s) \cong \frac{g_{md}(g_{mo} - sC_c)}{s^2 C_c C_L + s C_c (g_{mo} - \beta g_{md}) + \beta g_{md} g_{mo}}$$

Right Half-Plane Zero Limits Performance

- Why does the RHP zero limit performance ?
- Can anything be done about this problem ?
- Why is this not 3rd order since there are 3 caps ?

Review from last lecture

Why does the RHP zero limit performance ?

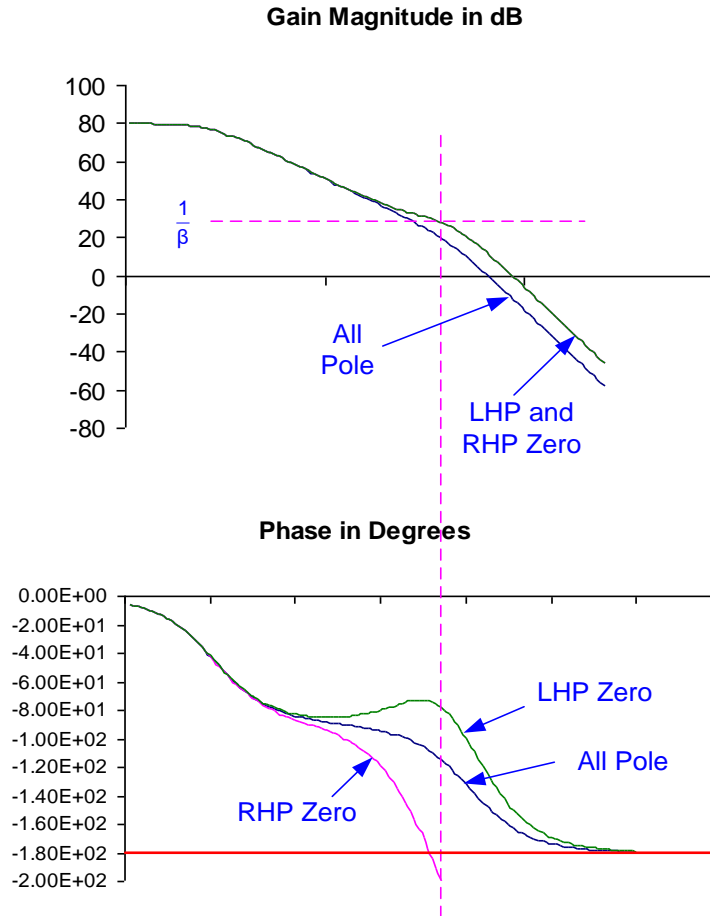

In this example:

- accumulate phase shift and slow gain drop with RHP zeros
- loose phase shift and slow gain drop with LHP zeros
- effects are dramatic

Two-stage amplifier with LHP Zero Compensation

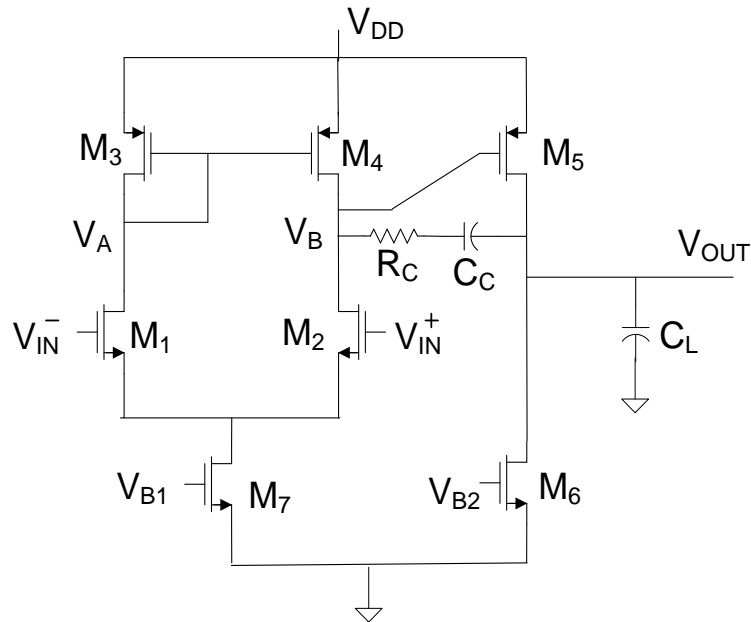

$$A(s) = \frac{g_{md} \left(g_{m5} + sC_c \left[\frac{g_{m5}}{g_c} - 1 \right] \right)}{s^2 C_c C_L + sC_c g_{m5} + g_{oo} g_{od}}$$

$$z_1 = \frac{-g_{m5}}{C_c \left[\frac{g_{m5}}{g_c} - 1 \right]}$$

z_1 location can be programmed by R_C

If $g_c > g_{m5}$, z_1 in RHP and if $g_c < g_{m5}$, z_1 in LHP

R_C has almost no effect on p_1 and p_2

Two-stage amplifier with LHP Zero Compensation

$$A(s) = \frac{g_{md} \left(g_{m5} + sC_c \left[\frac{g_{m5}}{g_c} - 1 \right] \right)}{s^2 C_c C_L + sC_c g_{m5} + g_{oo} g_{od}}$$

$$z_1 = \frac{-g_{m5}}{C_c \left[\frac{g_{m5}}{g_c} - 1 \right]}$$

$$p_1 = -\frac{g_{o1} + g_{o5}}{C_c \left(\frac{g_{m5}}{g_{o5} + g_{o6}} \right)}$$

$$p_2 = -\frac{g_{m5}}{C_L}$$

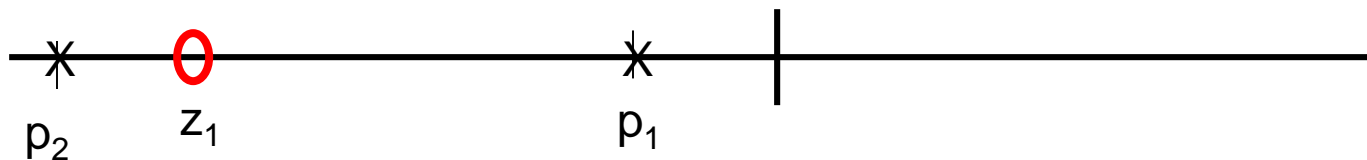

where should z_1 be placed?

Basic Two-Stage Op Amp with LHP zero

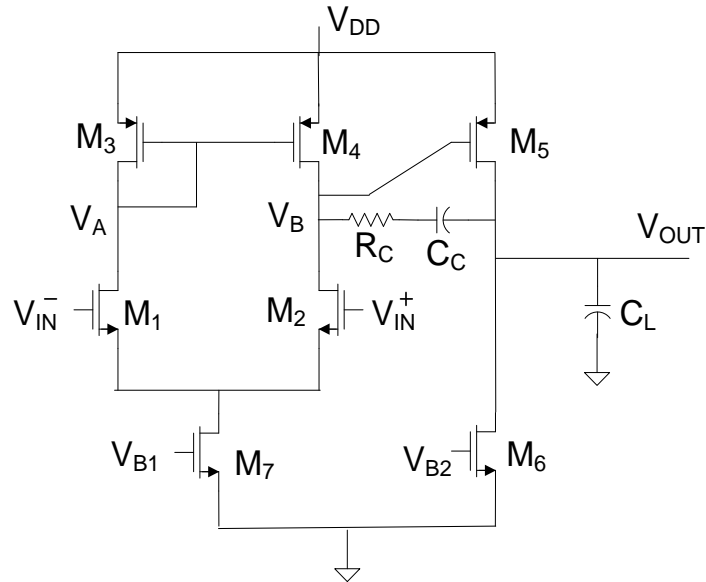

Realization of R_C

$$R_C = \frac{L}{\mu C_{OX} W V_{EB}}$$

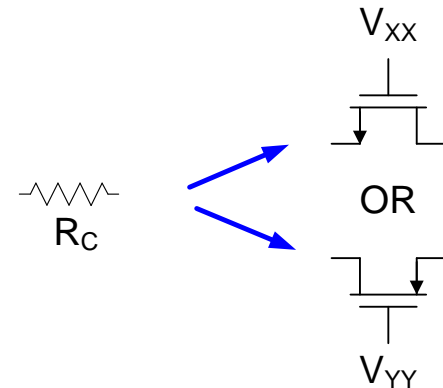

Transistors in triode region

Very little current will flow through transistors (and no dc current)

V_{DD} or GND often used for V_{XX} or V_{YY}

V_{BQ} well-established since it determines I_{Q5}

Using an actual resistor not a good idea (will not track gm5 over process and temp)

Open-loop gain simulations

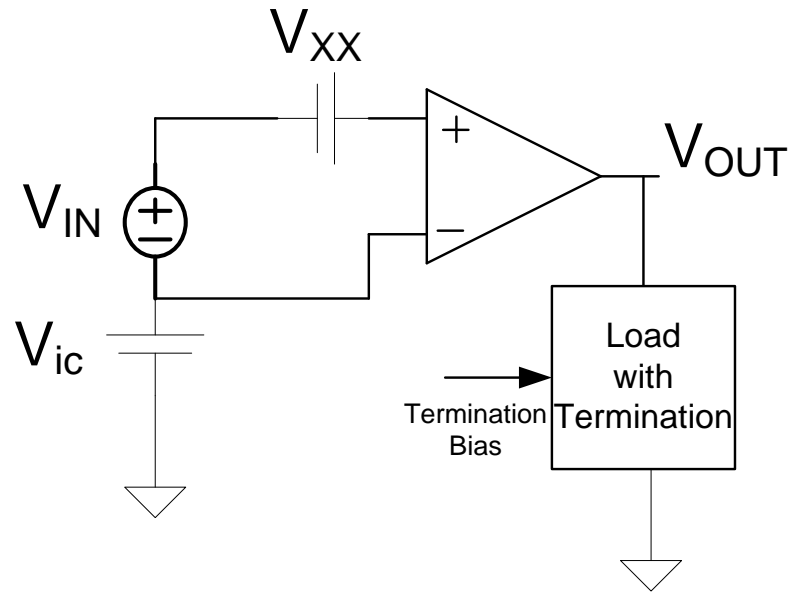

- Must first adjust V_{XX} to trim out any systematic offset
- Always verify all devices are operating in the desired region of operation
- If an ac input is applied to V_{IN} , no information about linearity or signal swing will be obtained
- If any changes in amplifier circuit are made, V_{XX} must be trimmed again
- Include any loading including loading of beta network (with proper termination)

Open-loop gain simulations

(with a closed-loop test bench)

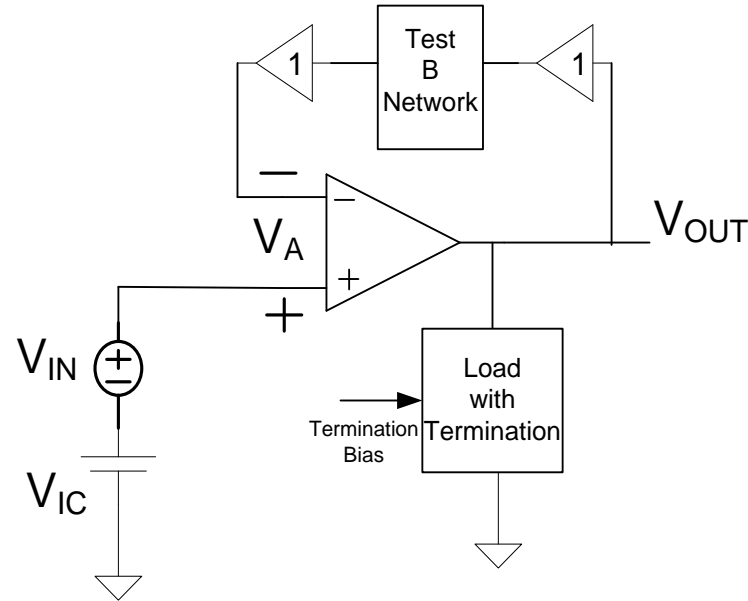

$$A_{VL} = \frac{V_{OUT}}{V_A}$$

- Stabilizes the effect of the systematic offset voltage
- Test β network may not be related to actual β at all
- Loading of actual β network included in “Load with Termination”
- Input and output buffers eliminate any loading effects of the test β network
- A_V must be calculated from measurements of V_{OUT} and V_A
- Test β network must be chosen so overall network is stable

Why not just use actual β network for test β network?

Actual β network may even be unstable before compensation is complete

Feedback simulations

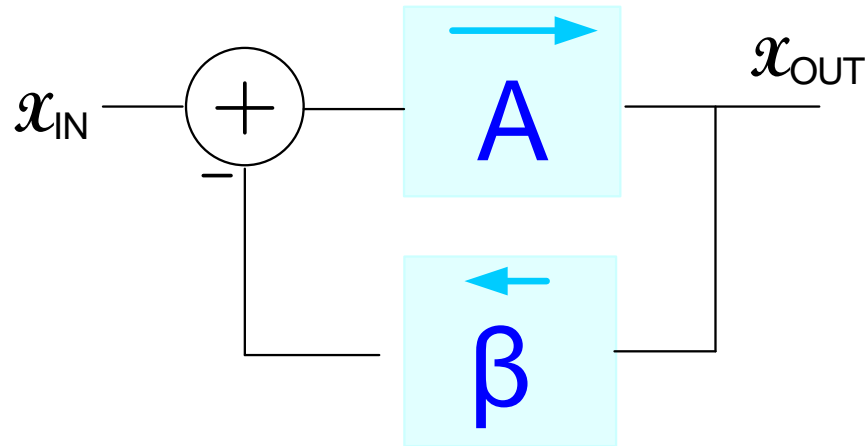

Why not just simulate the frequency response of the actual feedback amplifier and look at the magnitude of the gain to see if that is what we want ?

Isn't that what we really want anyway?

If the amplifier is overly underdamped or oscillatory, won't that show up anyway?

Remember, the small-signal analysis will have the same magnitude response for minimum-phase and non-minimum phase systems !

Tools for Helping with Amplifier Compensation



Numerous tools but generally require analytical models



Based upon testbenches using actual circuit schematics (though behavioral descriptions can be included)

STB (in Spectre)

The Spectre STB analysis provides a way to simulate continuous time loop gain, phase margin and gain margin without breaking the feedback loop.

In the stability analysis you are required to choose a probe from which the loop gain measurements are taken. The probes, described below, can be found in the analogLib

Many sources on line discussing STB analysis.

(One youtube video is listed below (without assessment of either validity or quality))

<https://youtu.be/L8wJhENPZNc>

Other Methods of Gain Enhancement

$$A_{V0} = \frac{-g_{MQC}}{g_{OQC} + g_{OCC}} \quad \longrightarrow \quad A_{V0} = \frac{-g_{MQC1}}{g_{OQC1} + g_{OCC1}} \cdot \frac{-g_{MQC2}}{g_{OQC2} + g_{OCC2}}$$

Methods used so far:

Increasing the output impedance of the amplifier
cascode, folded cascode, regulated cascode

Increasing the transconductance
(current mirror op amp) but it didn't really help because
the output conductance increased proportionally

Cascading gives a multiplicative gain effect
(thousands of architectures but compensation is essential)
practically limited to a two-level cascade because of too much
phase accumulation

Recall:

Other Methods of Gain Enhancement

Recall:

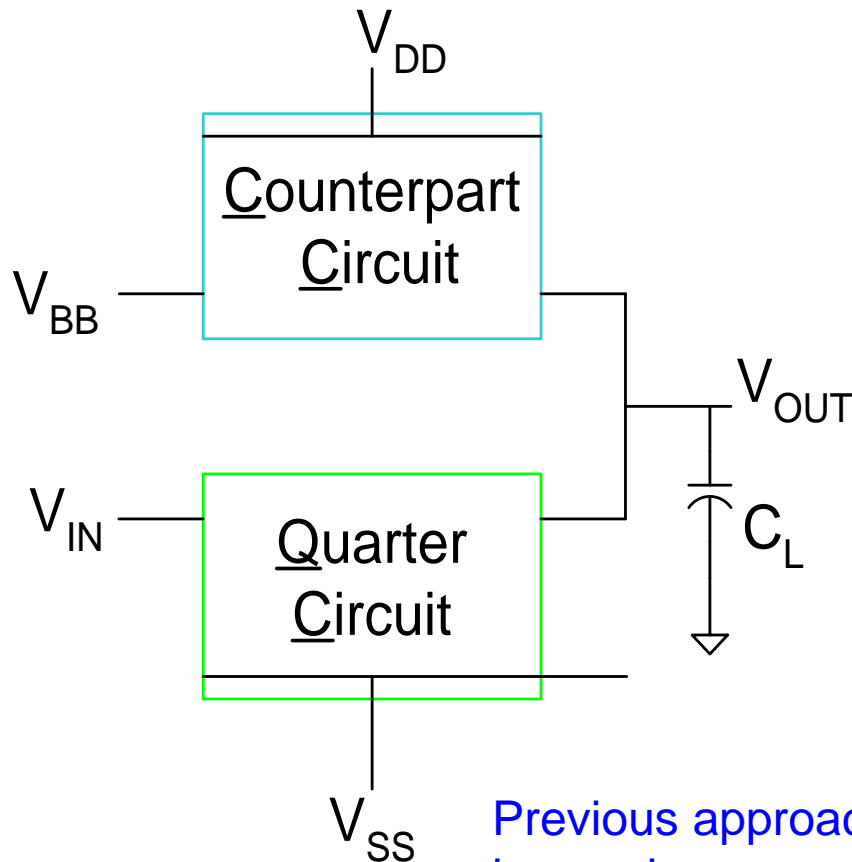

$$A_{V0} = \frac{-g_{mQC}}{g_{oQC} + g_{oCC}}$$

$$GB = \frac{g_{mQC}}{C_L}$$

Two Strategies:

1. Decrease denominator of A_{V0}
2. Increase numerator of A_{V0}

Previous approaches focused on decreasing denominator or increasing numerator with current mirror

Consider now increasing numerator with excitation

Other Methods of Gain Enhancement

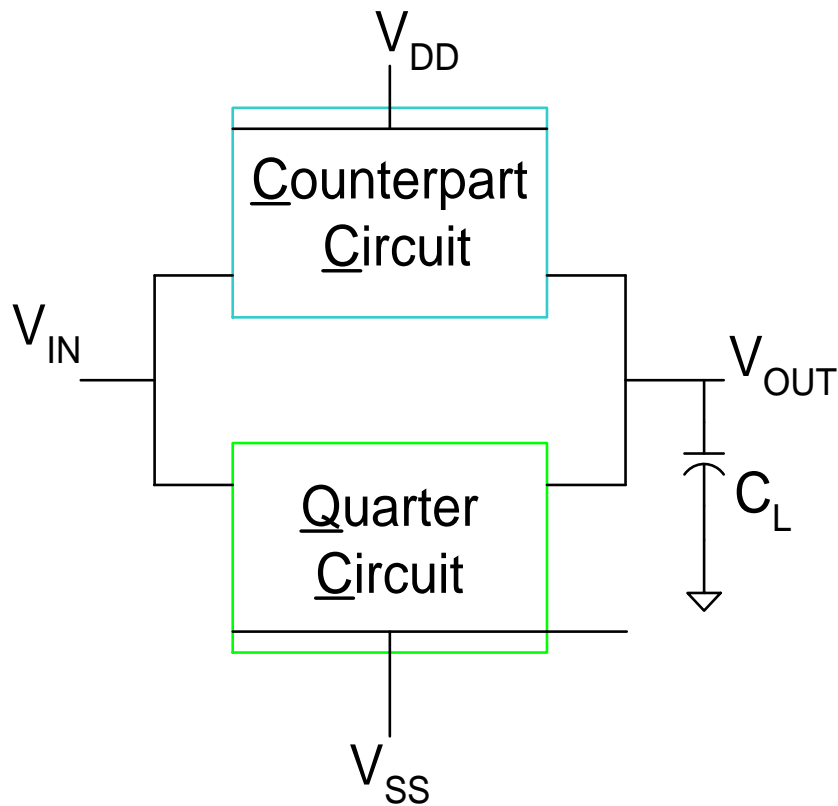

$$A_{v0} = \frac{-(g_{mQC} + g_{mCC})}{g_{oQC} + g_{oCC}}$$

$$GB = \frac{g_{mQC} + g_{mCC}}{C_L}$$

**Consider now increasing numerator
by changing the excitation**

g_{meq} Enhancement with Driven Counterpart Circuit

Recall:

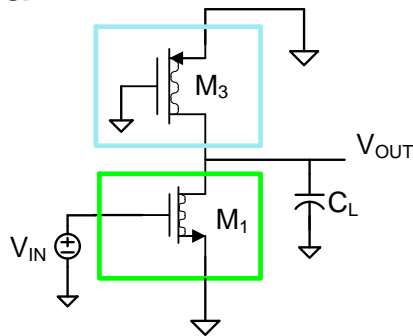

$$A_{V0} = \frac{g_{m1}}{g_{o1} + g_{o3}}$$

$$GB = \frac{g_{m1}}{C_L}$$

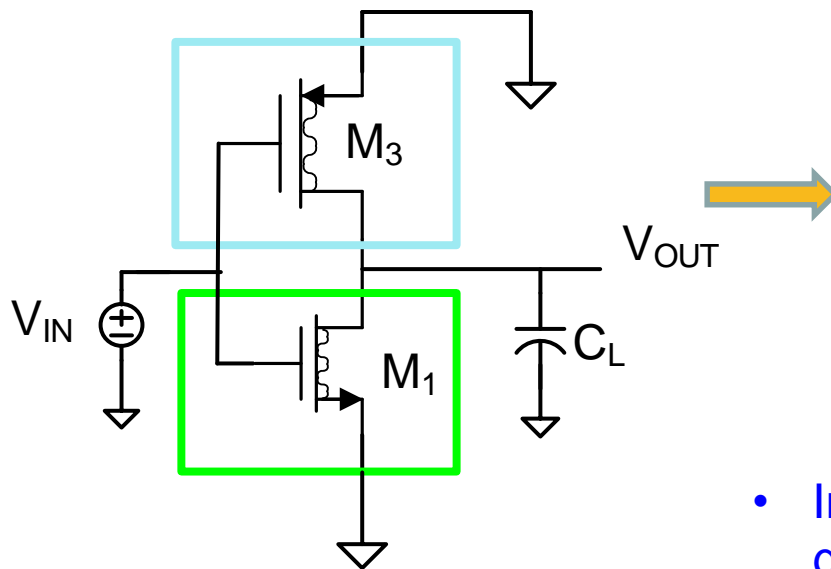

$$A_{V0} = \frac{g_{m1} + g_{m3}}{g_{o1} + g_{o3}}$$

$$GB = \frac{g_{m1} + g_{m3}}{C_L}$$

- In the small-signal parameter domain, both gain and GB appear to be enhancement
- Is this real?

g_{meq} Enhancement with Driven Counterpart Circuit

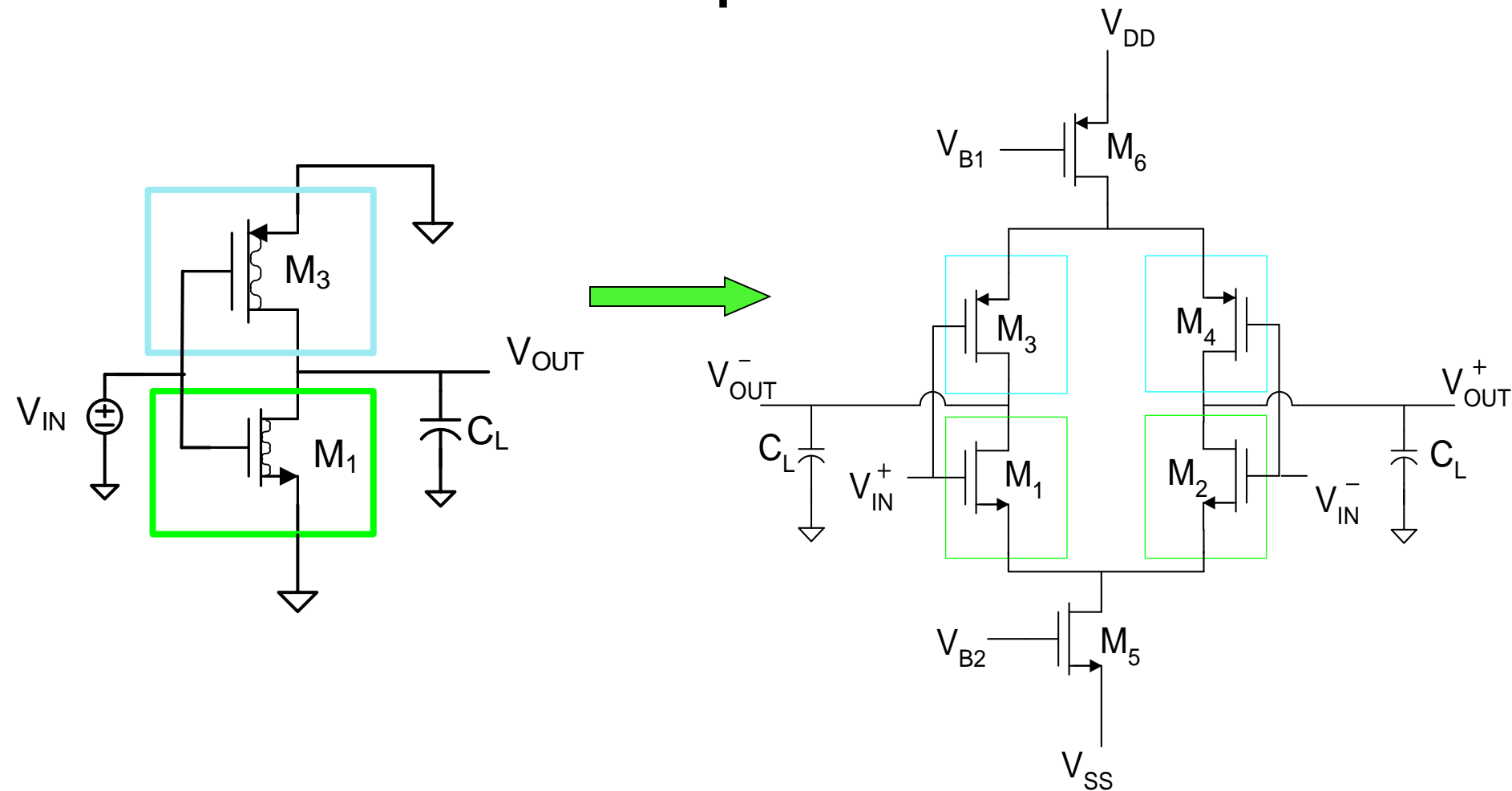

Needs CMFB Circuit to V_{B1} or V_{B2}

g_{meq} Enhancement with Driven Counterpart Circuit

Is this real?

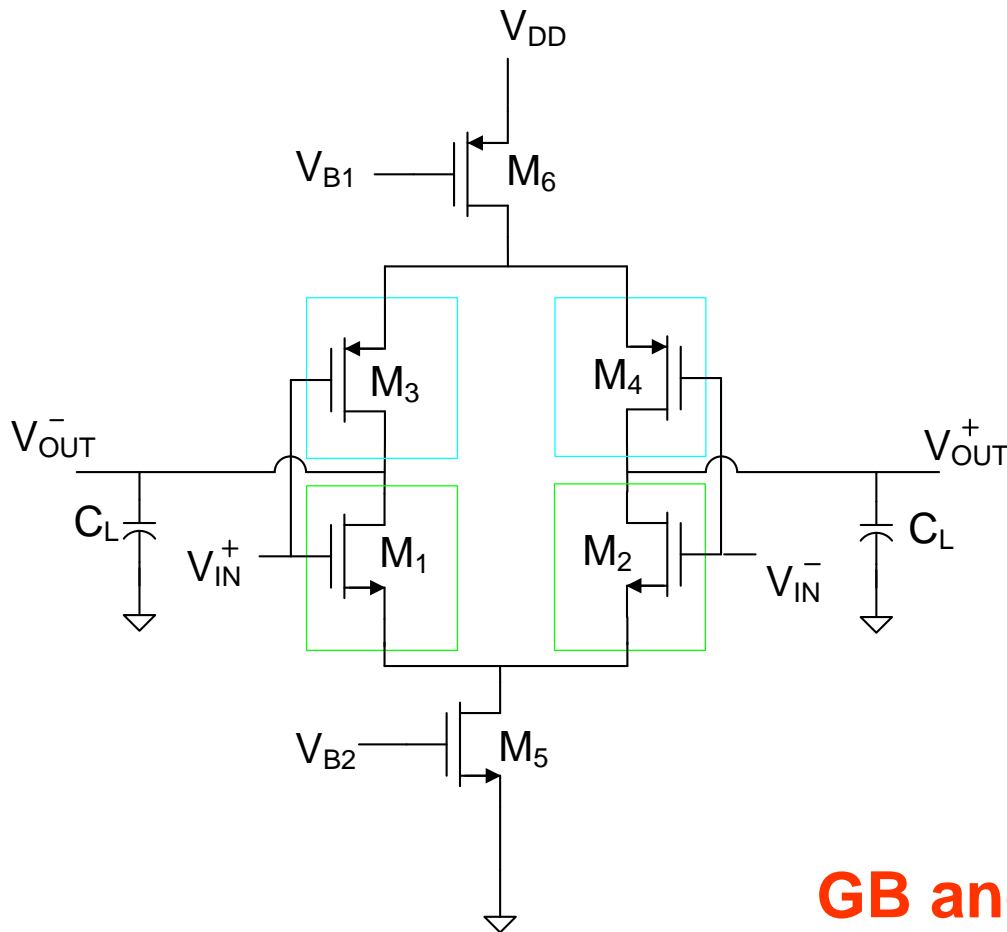

$$A_{V0} = \frac{1}{2} \frac{g_{m1} + g_{m3}}{g_{o1} + g_{o3}}$$

$$GB = \frac{1}{2} \frac{g_{m1} + g_{m3}}{C_L}$$

$$A_{V0} = \frac{1}{V_{EB1}} + \frac{1}{V_{EB3}}$$

$$GB = \left[\frac{P}{2V_{DD}C_L} \right] \left(\frac{1}{V_{EB1}} + \frac{1}{V_{EB3}} \right)$$

GB and A_{V0} improved !

Other Methods of Gain Enhancement

Increasing the output impedance of the amplifier
cascode, folded cascode, regulated cascode

Increasing the transconductance
(current mirror op amp) but it didn't really help because
the output conductance increased proportionally



Driving the counterpart circuit does offer some improvements in gain

Cascading gives a multiplicative gain effect
(thousands of architectures but compensation is essential)
practically limited to a two-level cascade because of too much
phase accumulation

Recall:

Other Methods of Gain Enhancement

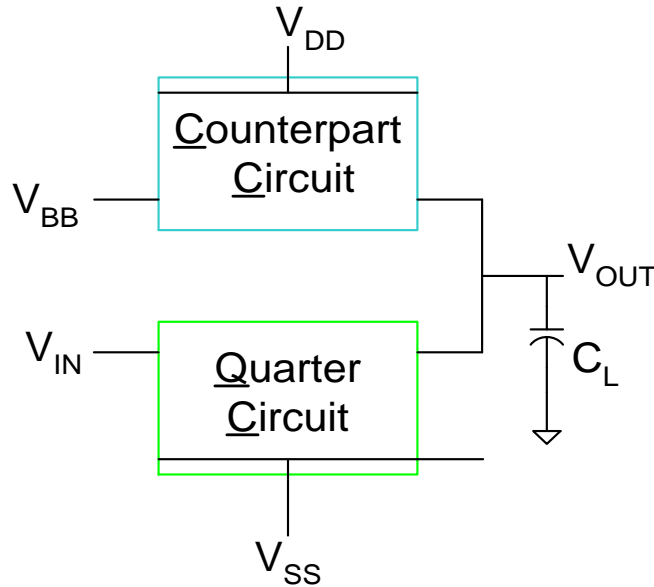

$$A_{V0} = \frac{-g_{MQC}}{g_{OQC} + g_{OCC}}$$

Two Strategies:

1. Decrease denominator of A_{V0}
2. Increase numerator of A_{V0}

Consider again decreasing the denominator

$$A_{V0} = \frac{-g_{MQC}}{g_{OQC} + g_{OCC} - g_{OX}}$$

Is it possible to come up with circuits that will provide a subtraction of conductance in the denominator ?

Other Methods of Gain Enhancement

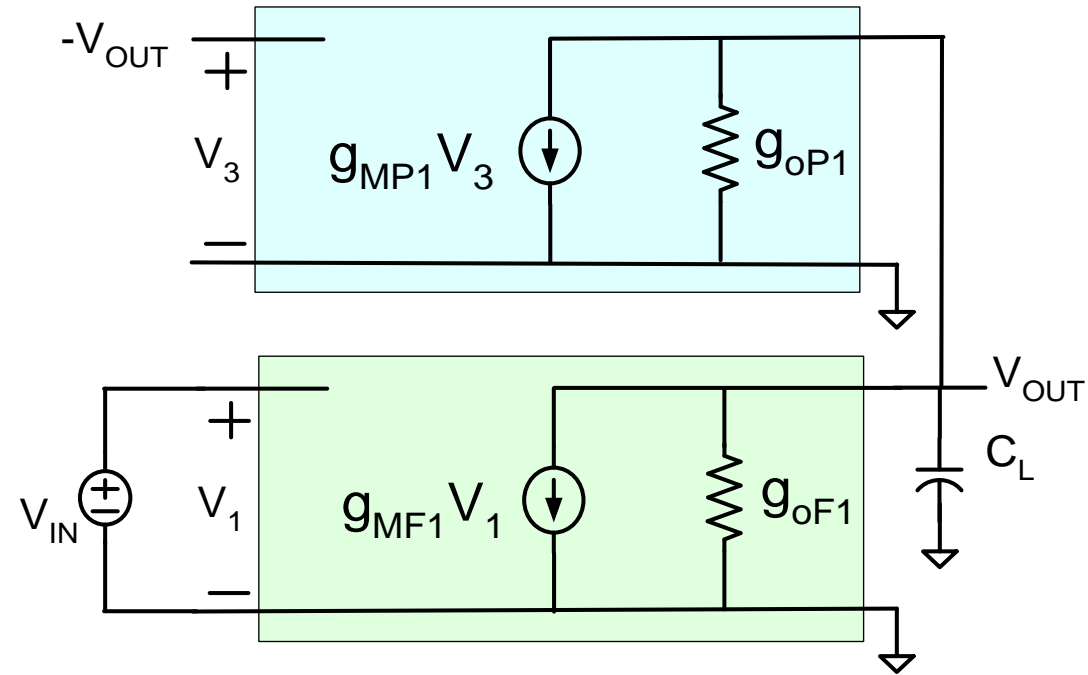
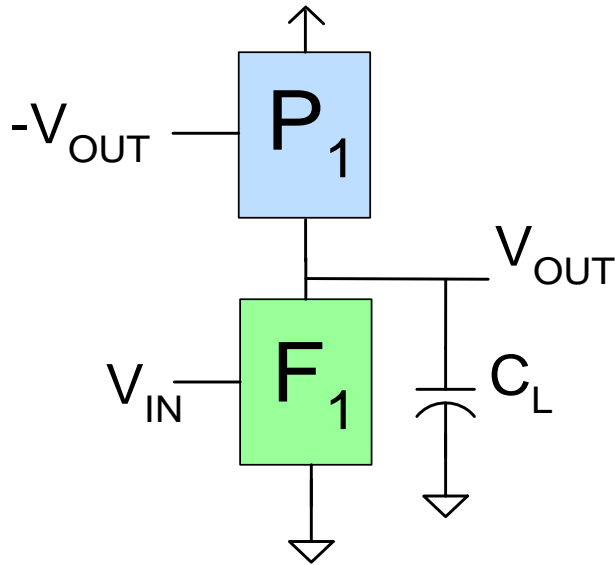

$$\left. \begin{aligned} V_{OUT}(sC_L + g_{oP1} + g_{oF1}) + g_{mF1} V_{IN} + g_{mP1} V_3 &= 0 \\ V_3 &= -V_{OUT} \end{aligned} \right\}$$

$$A_V(s) = \frac{-g_{MQC}}{sC_L + g_{OQC} + g_{OCC} - g_{MCC}}$$

$$A_V(s) = \frac{-g_{mF1}}{sC_L + g_{oF1} + g_{oP1} - g_{mP1}}$$

Gain Enhancement with Regenerative Feedback

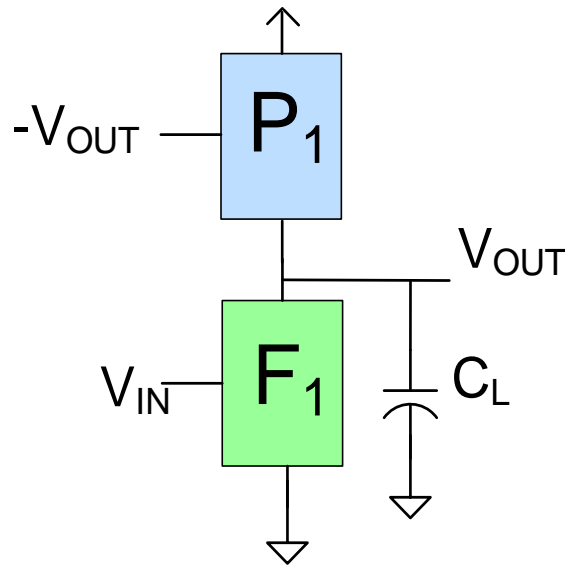

$$A_{V0} = \frac{-g_{mF1}}{sC_L + g_{oF1} + g_{oP1} - g_{mP1}}$$

$$A_{V0} = \frac{g_{mF1}}{g_{oF1} + g_{oP1} - g_{mP1}}$$

$$BW = \frac{g_{oF1} + g_{oP1} - g_{mP1}}{C_L}$$

$$GB = \frac{g_{mF1}}{C_L}$$

The gain can be made arbitrarily large by selecting g_{mP1} appropriately

The GB does not degrade !

But if not careful, maybe g_{mP1} will get too large!

Gain Enhancement with Regenerative Feedback

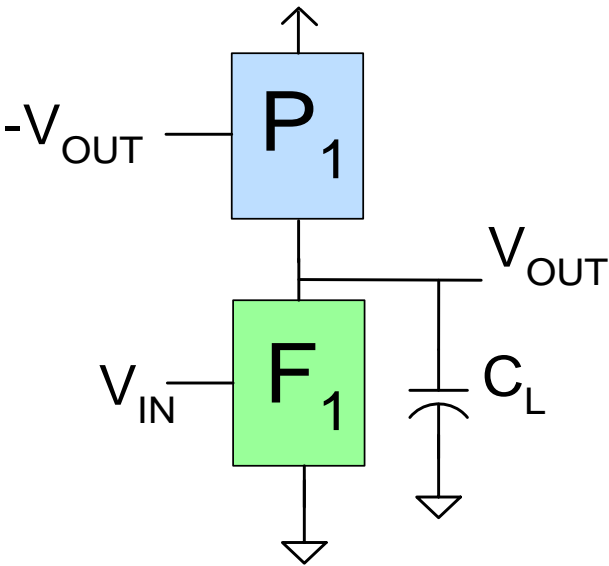

$$A_{V0} = \frac{-g_{mF1}}{sC_L + g_{oF1} + g_{oP1} - g_{mP1}}$$

$$A_{V0} = \frac{g_{mF1}}{g_{oF1} + g_{oP1} - g_{mP1}}$$

$$BW = \frac{g_{oF1} + g_{oP1} - g_{mP1}}{C_L}$$

$$GB = \frac{g_{mF1}}{C_L}$$



The gain can be made arbitrarily large by selecting g_{mP1} appropriately

The GB does not degrade !

This circuit has a positive feedback loop ($V_{INP1}:V_{OUT}:-V_{OUT}$)

But - can we easily build circuits with this property?

Gain Enhancement with Regenerative Feedback

But - can we easily build circuits with this property?

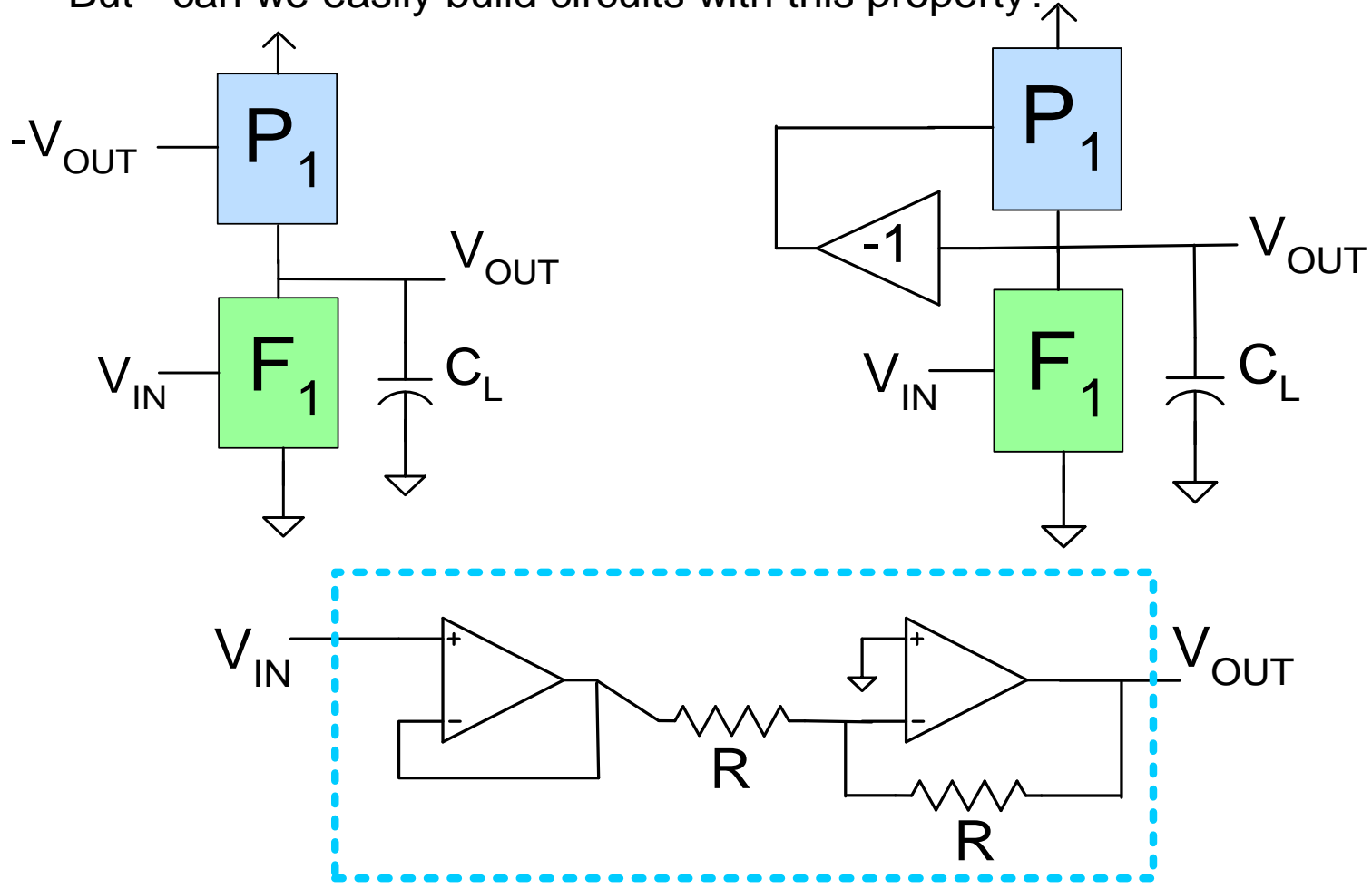

But – the inverting amplifier may be more difficult to build than the op amp itself!

Do we need 2 op amps, one with an output buffer to drive the R resistors?

Gain Enhancement with Regenerative Feedback

But - can we easily build circuits with this property?

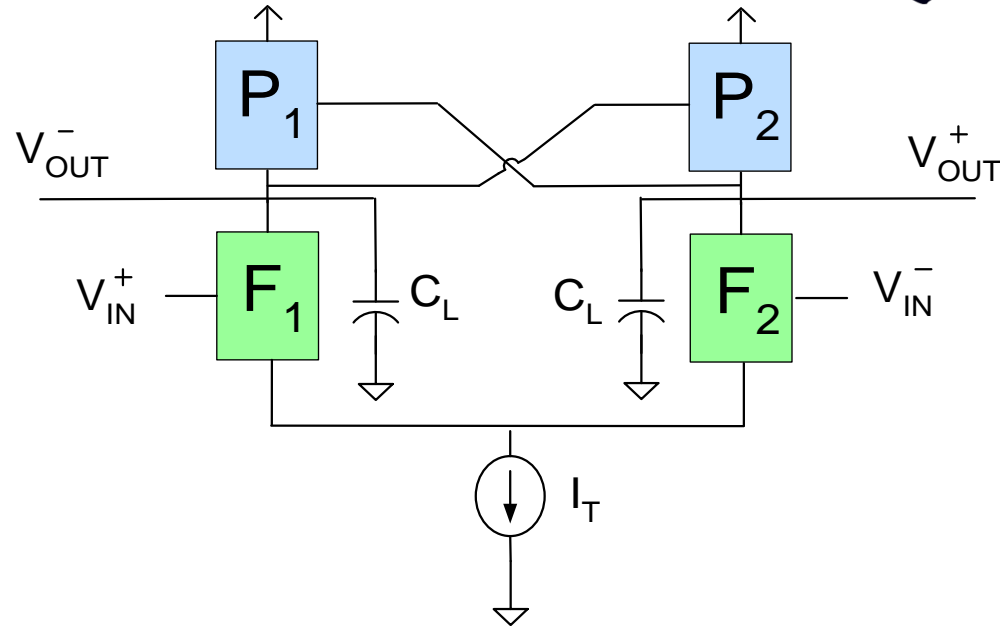
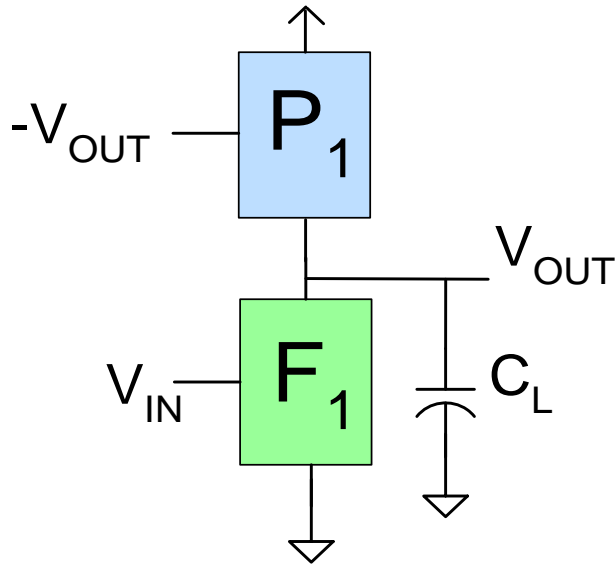

But – the inverting amplifier may be more difficult to build than the op amp itself!

YES – simply by cross-coupling the outputs in a fully differential structure

Gain Enhancement with Regenerative Feedback

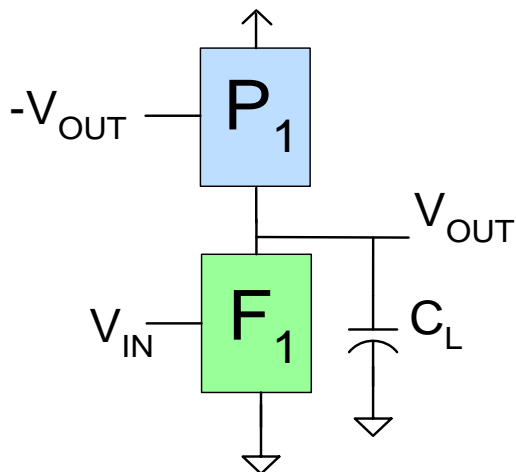

$$A_{V0}(s) = \frac{-g_{mF1}}{sC_L + g_{oF1} + g_{oP1} - g_{mP1}}$$

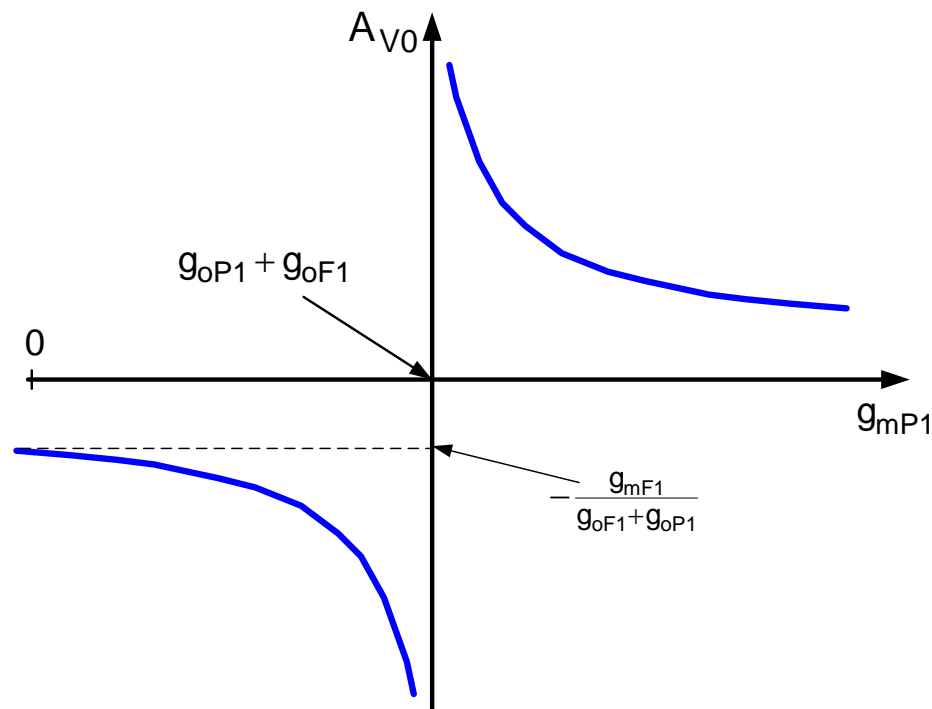

If $g_{mP1} = g_{oF1} + g_{oP1}$, the dc gain will become infinite !!

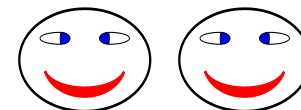

Gain Enhancement with Regenerative Feedback

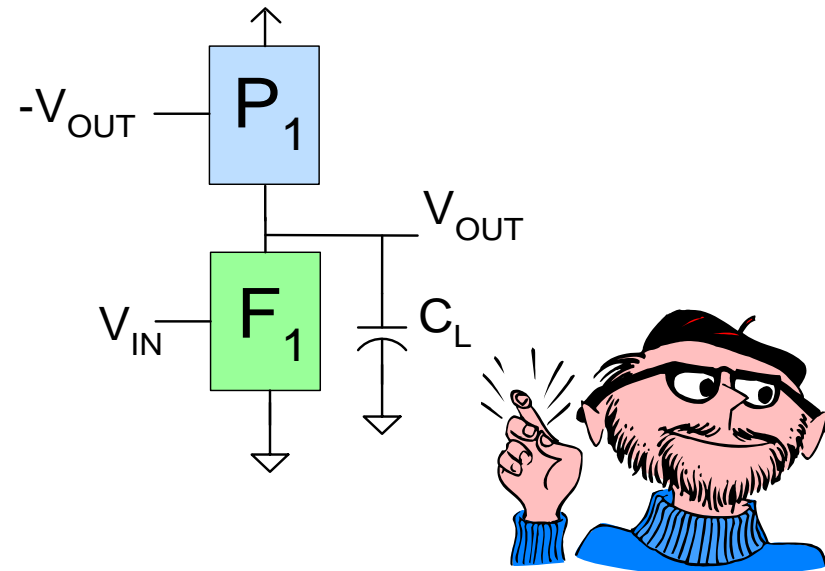

$$A_{V0}(s) = \frac{-g_{mF1}}{sC_L + g_{oF1} + g_{oP1} - g_{mP1}}$$

$$p = \frac{-g_{oF1} - g_{oP1} + g_{mP1}}{C_L}$$

If $g_{mP1} > g_{oF1} + g_{oP1}$, the pole will be in the RHP !!

This will make the op amp unstable



Positive Feedback is BAD !!



This is the major reason most have avoided using the structure !

Gain Enhancement with Regenerative Feedback

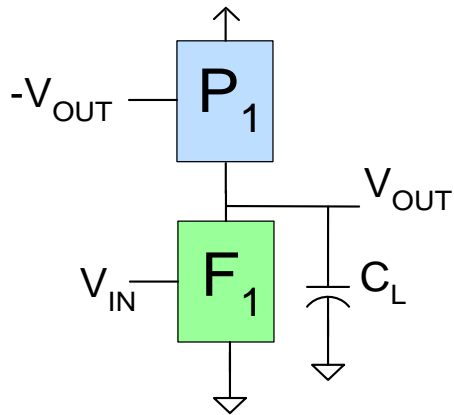

This will make the op amp unstable



Positive Feedback is BAD !!



This is the major reason most have avoided using the structure !



But is Positive Feedback really bad?

Remember – Why do we want a large Op Amp Gain Anyway?

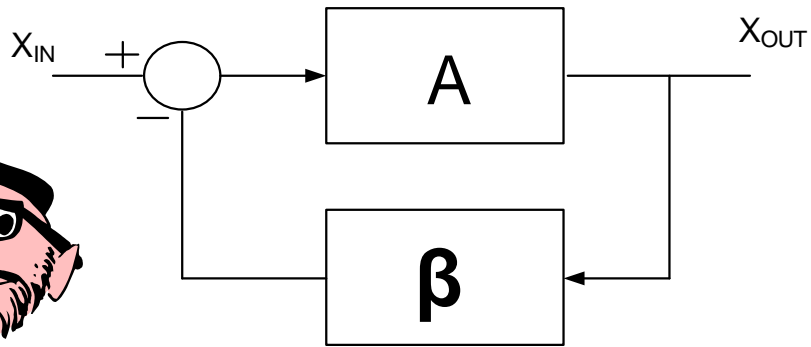

$$A_{FB} = \frac{A}{1 + A\beta}$$

To make A_{FB} very close to $1/\beta$

Even when standard $A_{VFB} = \frac{A_{OL}}{1 + A_{OL}\beta}$ equation does not apply

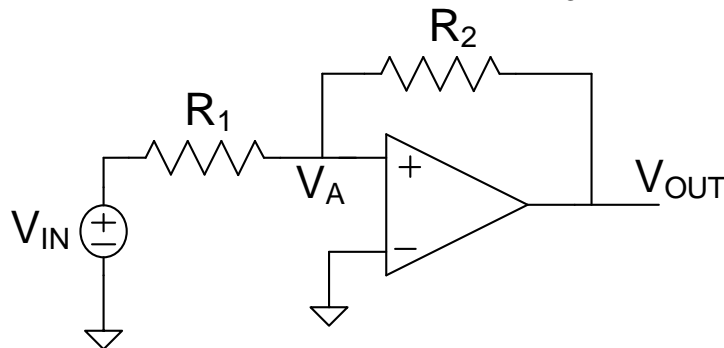

Want A_{OL} large to make V_A very close to 0 so A_{VFB} very close to $-R_2/R_1$

Gain Enhancement with Regenerative Feedback

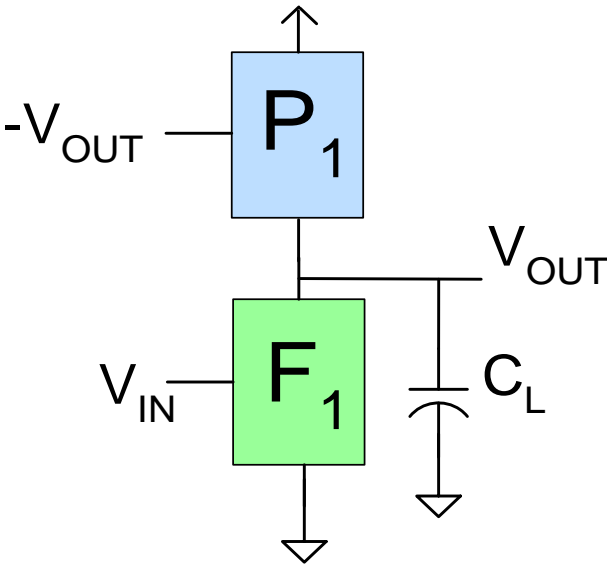

$$A_{V0}(s) = \frac{-g_{mF1}}{sC_L + g_{oF1} + g_{oP1} - g_{mP1}}$$

$$p = \frac{-g_{oF1} - g_{oP1} + g_{mP1}}{C_L}$$

If $g_{mP1} > g_{oF1} + g_{oP1}$, the pole will be in the RHP !!

It can be shown that the feedback amplifier is usually stable even if the open-loop Op amp is unstable

The feedback performance can actually be enhanced if the open-loop amplifier is unstable

Research has been ongoing recently using this approach and it shows considerable promise for gain enhancement in low voltage processes

Gain Enhancement with Regenerative Feedback

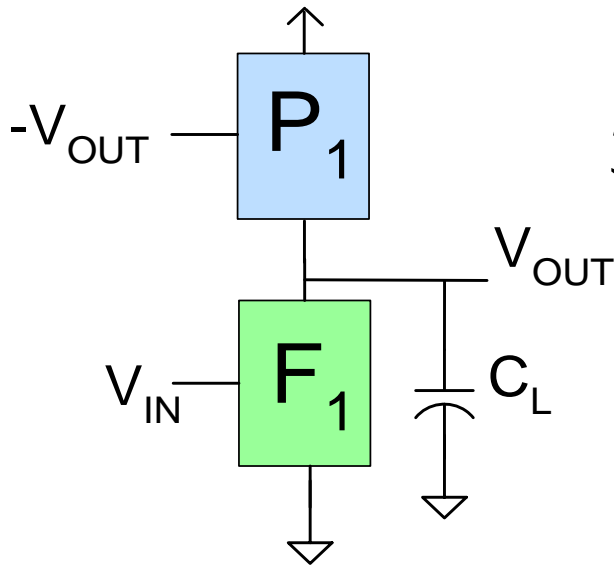

$$A_{V0}(s) = \frac{-g_{mF1}}{sC_L + g_{oF1} + g_{oP1} - g_{mP1}}$$

$$p = \frac{-g_{oF1} - g_{oP1} + g_{mP1}}{C_L}$$

If $g_{mP1} > g_{oF1} + g_{oP1}$, the pole will be in the RHP !!

It can be shown that the feedback amplifier is usually stable even if the open-loop Op amp is unstable **How?**

Recall: The numerator of A_{V0} does not change signs when the constant term in the denominator transitions from positive to negative with this approach

$$A_{V0}(s) = \begin{cases} \frac{A_{V0}\tilde{p}_1}{(s + \tilde{p}_1)} & \text{for } \tilde{p}_1 > 0 \\ \frac{-A_{V0}\tilde{p}_1}{(s + \tilde{p}_1)} & \text{for } \tilde{p}_1 < 0 \end{cases}$$

Gain Enhancement with Regenerative Feedback

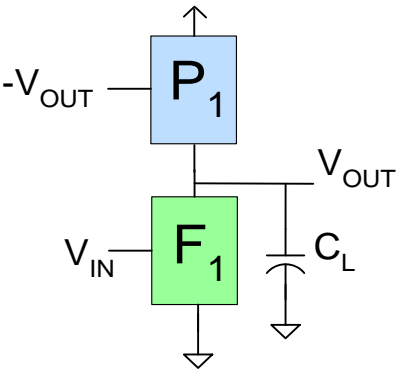

It can be shown that the feedback amplifier is usually stable even if the open-loop Op amp is unstable



How?

$$A_{V0}(s) = \begin{cases} \frac{A_{V0}\tilde{p}_1}{(s + \tilde{p}_1)} & \text{for } \tilde{p}_1 > 0 \\ \frac{-A_{V0}\tilde{p}_1}{(s + \tilde{p}_1)} & \text{for } \tilde{p}_1 < 0 \end{cases}$$

$$A_{FB}(s) = \begin{cases} \frac{A_{V0}\tilde{p}_1}{s + \tilde{p}_1(1 + \beta A_{V0})} & \text{for } \tilde{p}_1 > 0 \\ \frac{-A_{V0}\tilde{p}_1}{s + \tilde{p}_1(1 - \beta A_{V0})} & \text{for } \tilde{p}_1 < 0 \end{cases}$$

$$p_{FB} = \begin{cases} -\tilde{p}_1(1 + \beta A_{V0}) = p_1(1 + \beta A_{V0}) & \text{for } p_1 < 0 \\ -\tilde{p}_1(1 - \beta A_{V0}) = p_1(1 - \beta A_{V0}) & \text{for } p_1 > 0 \end{cases}$$

Gain Enhancement with Regenerative Feedback

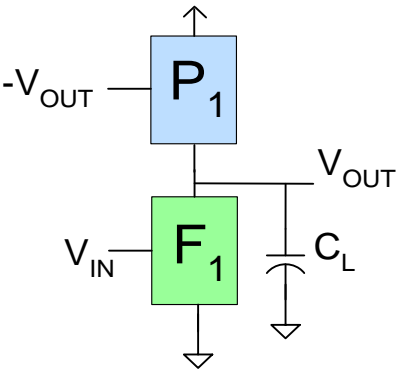

It can be shown that the feedback amplifier is usually stable even if the open-loop Op amp is unstable



How?

$$p_{FB} = \begin{cases} -\tilde{p}_1 (1 + \beta A_{V0}) = p_1 (1 + \beta A_{V0}) & \text{for } p_1 < 0 \\ -\tilde{p}_1 (1 - \beta A_{V0}) = p_1 (1 - \beta A_{V0}) & \text{for } p_1 > 0 \end{cases}$$

Open-Loop and Closed-Loop Pole Plot for equal open-loop pole magnitudes

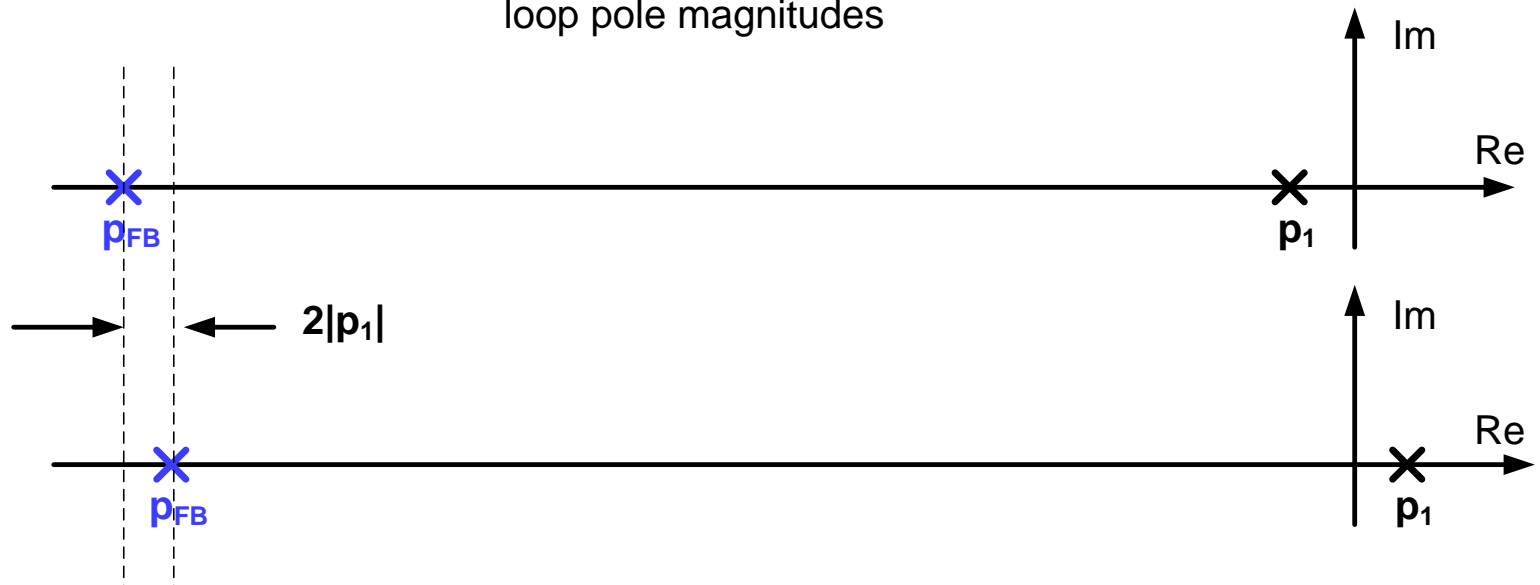

Gain Enhancement with Regenerative Feedback

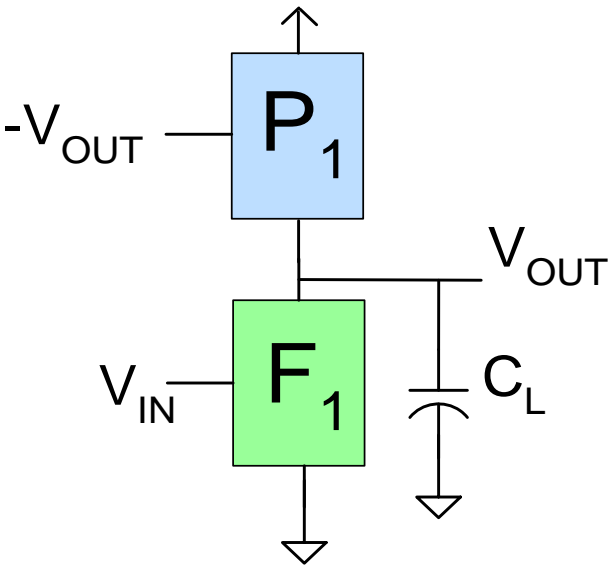

$$A_{V0} = \frac{-g_{mF1}}{sC_L + g_{oF1} + g_{oP1} - g_{mP1}}$$

$$p = \frac{-g_{oF1} - g_{oP1} + g_{mP1}}{C_L}$$

If $g_{mP1} > g_{oF1} + g_{oP1}$, the pole will be in the RHP !!

The feedback performance can actually be enhanced if the open-loop amplifier is unstable

Why?

Gain Enhancement with Regenerative Feedback

The feedback performance can actually be enhanced if the open-loop amplifier is unstable

Why?

$$A_{FB}(s) = \begin{cases} \frac{A_{V0}\tilde{p}_1}{s + \tilde{p}_1(1 + \beta A_{V0})} & \text{for } \tilde{p}_1 > 0 \\ \frac{-A_{V0}\tilde{p}_1}{s + \tilde{p}_1(1 - \beta A_{V0})} & \text{for } \tilde{p}_1 < 0 \end{cases}$$

$$\frac{-A_{V0}\tilde{p}_1}{\tilde{p}_1(1 - \beta A_{V0})} = \frac{A_{V0}}{\beta A_{V0} - 1} > \frac{1}{\beta}$$

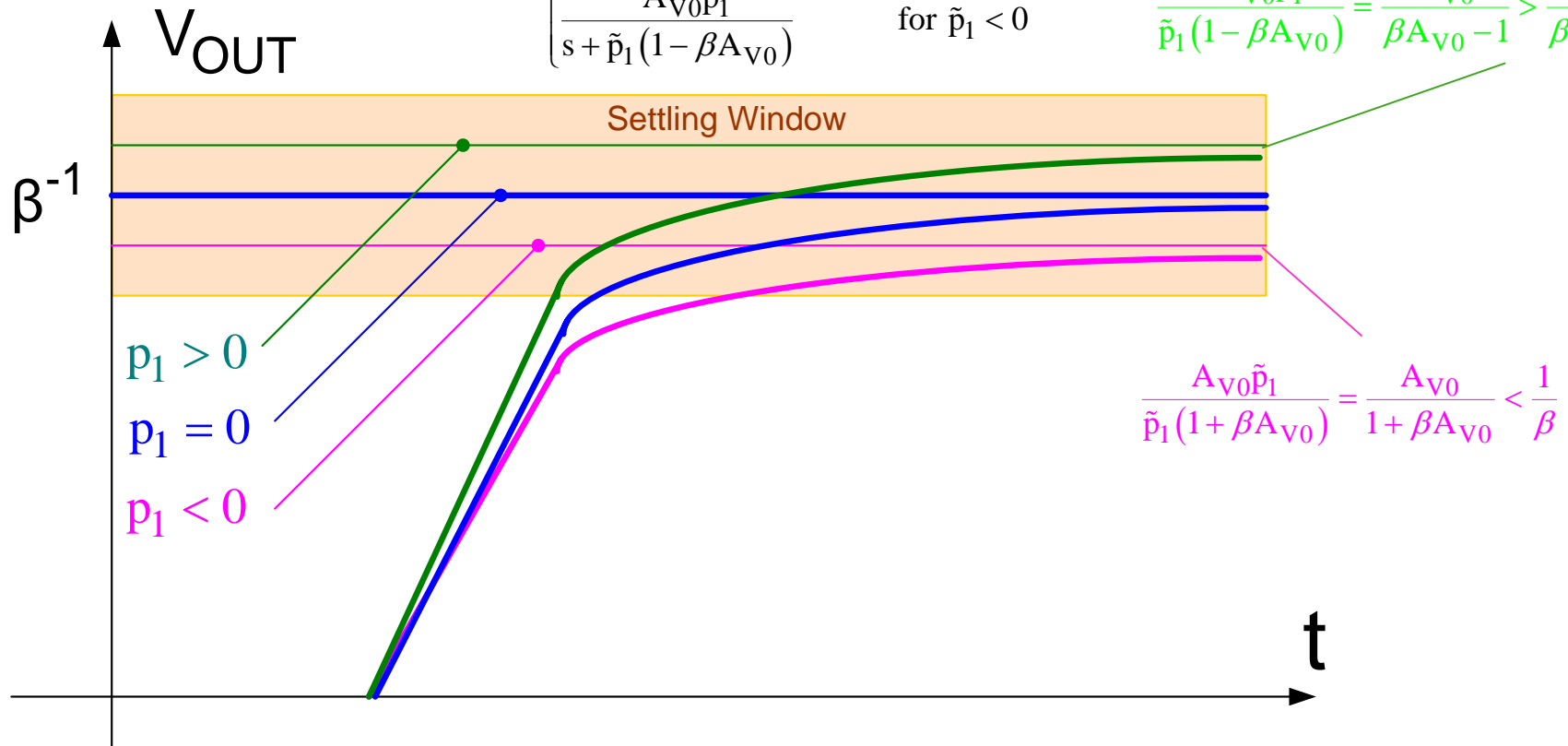

Gain Enhancement with Regenerative Feedback

The feedback performance can actually be enhanced if the open-loop amplifier is unstable

Why?

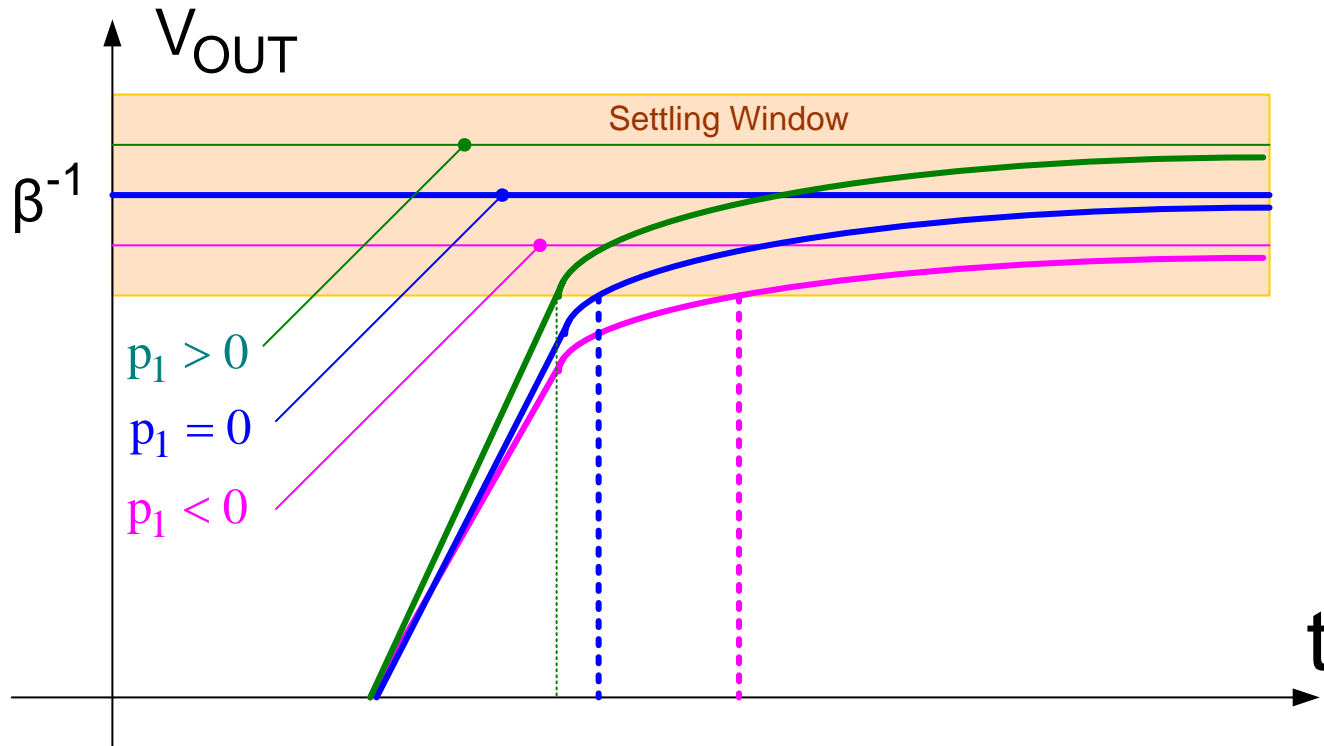

- Time required to get in settling window can be reduced with RHP pole
- But, if pole is too far in RHP, response will exit top of window

Some Half-Circuits with Interesting Potential

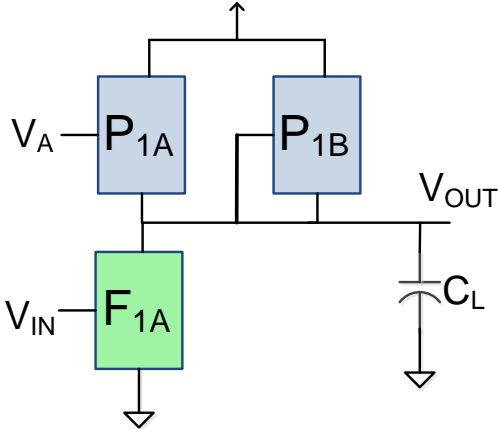
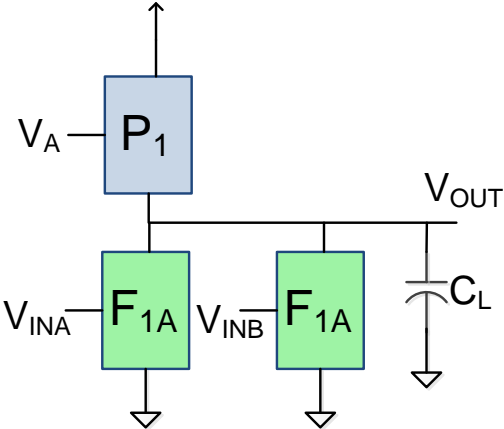
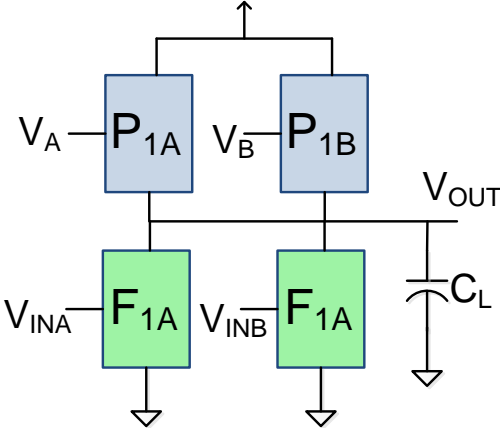
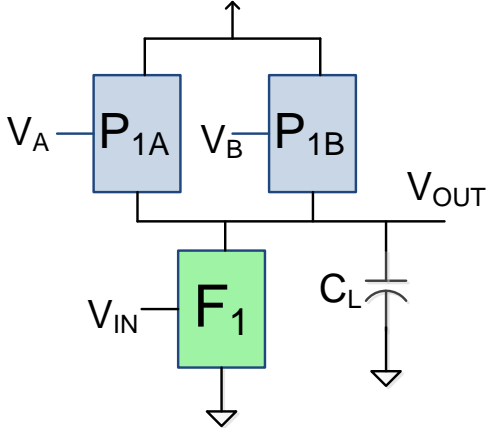
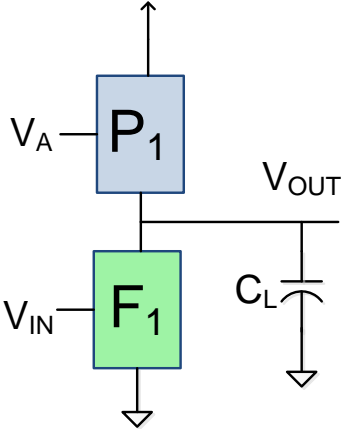

Existing Positive Feedback Amplifier

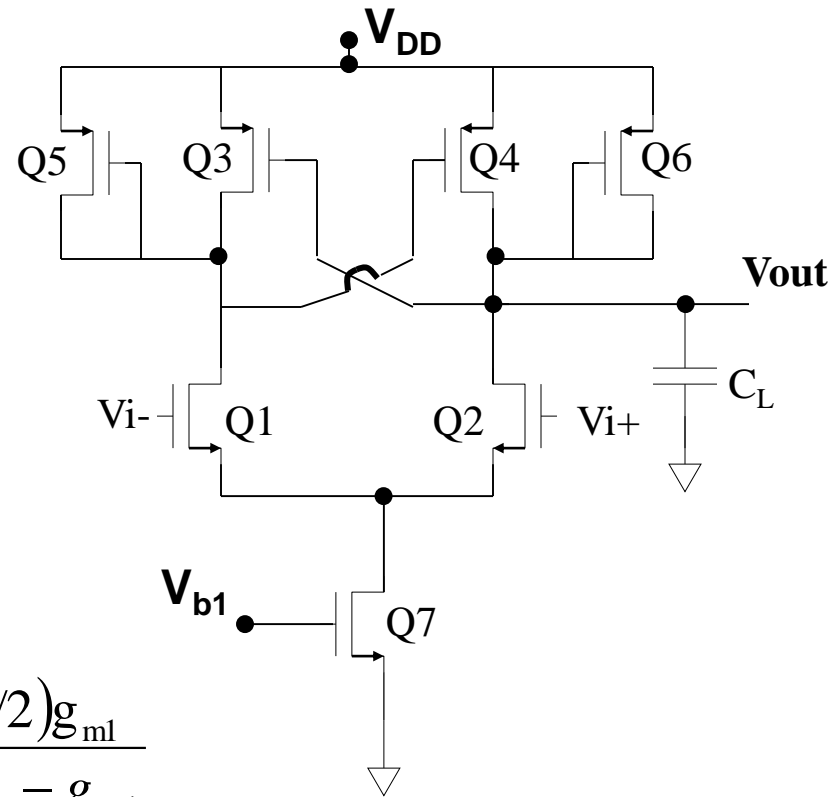

$$A_{VO} = \frac{(1/2)g_{m1}}{g_{o2} + g_{o4} + g_{o6} + g_{m6} - g_{m4}} \approx \frac{(1/2)g_{m1}}{g_{m6} - g_{m4}}$$

$$A(s) = \frac{(1/2)g_{m1}}{sC_L + [g_{o2} + g_{o4} + g_{o6} + g_{m6} - g_{m4}]}$$

Existing Positive Feedback Amplifier

$$A_{VO} = \frac{(1/2)g_{m1}}{g_{o2} + g_{o4} + g_{o6} + g_{m6} - g_{m4}} \approx \frac{(1/2)g_{m1}}{g_{m6} - g_{m4}}$$

$$A(s) = \frac{(1/2)g_{m1}}{sC_L + [g_{o2} + g_{o4} + g_{o6} + g_{m6} - g_{m4}]}$$

- Requires precise matching of g_{m4} to $(g_{o2} + g_{o4} + g_{o6} + g_{m6})$ for good gain enhancement
- Difficult to match g_m terms to g_o -type terms

Alternate Positive Feedback Amplifier

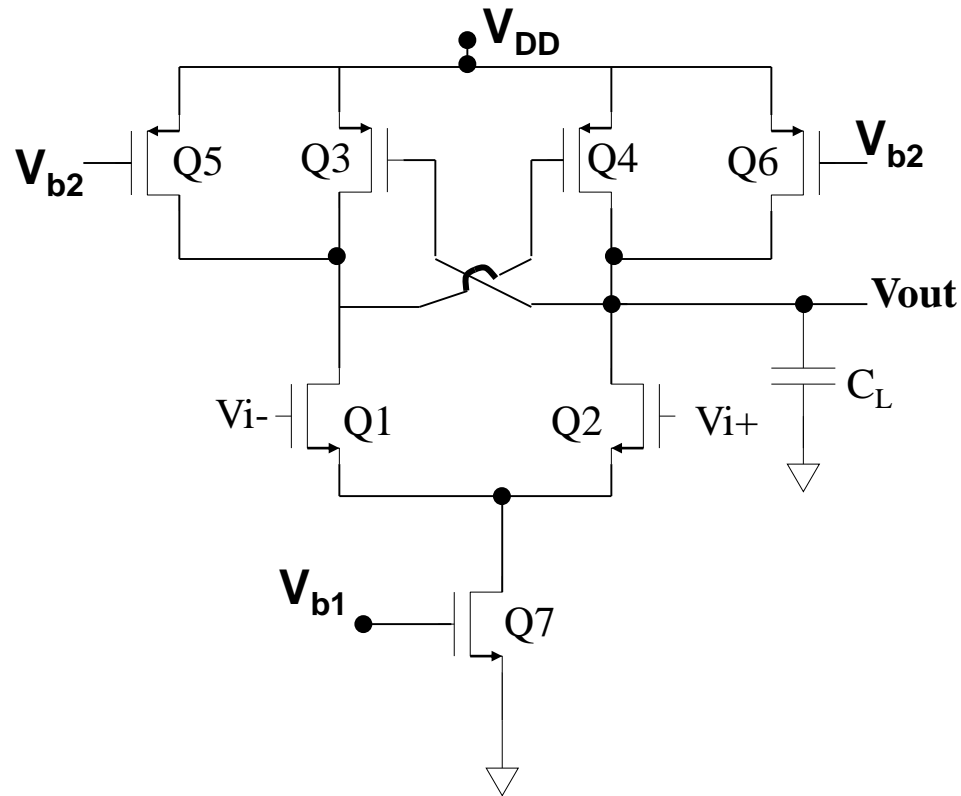

Alternate Positive Feedback Amplifier

$$A_{VO} = \frac{(1/2)g_{m1}}{g_{o2} + g_{o4} + g_{o6} - g_{m4}}$$

$$A(s) = \frac{(1/2)g_{m1}}{sC_L + [g_{o2} + g_{o4} + g_{o6} - g_{m4}]}$$

- Requires precise matching of g_{m4} to $(g_{o2} + g_{o4} + g_{o6})$ for good gain enhancement
- Difficult to match g_m terms to g_o -type terms

Another Positive Feedback Amplifier

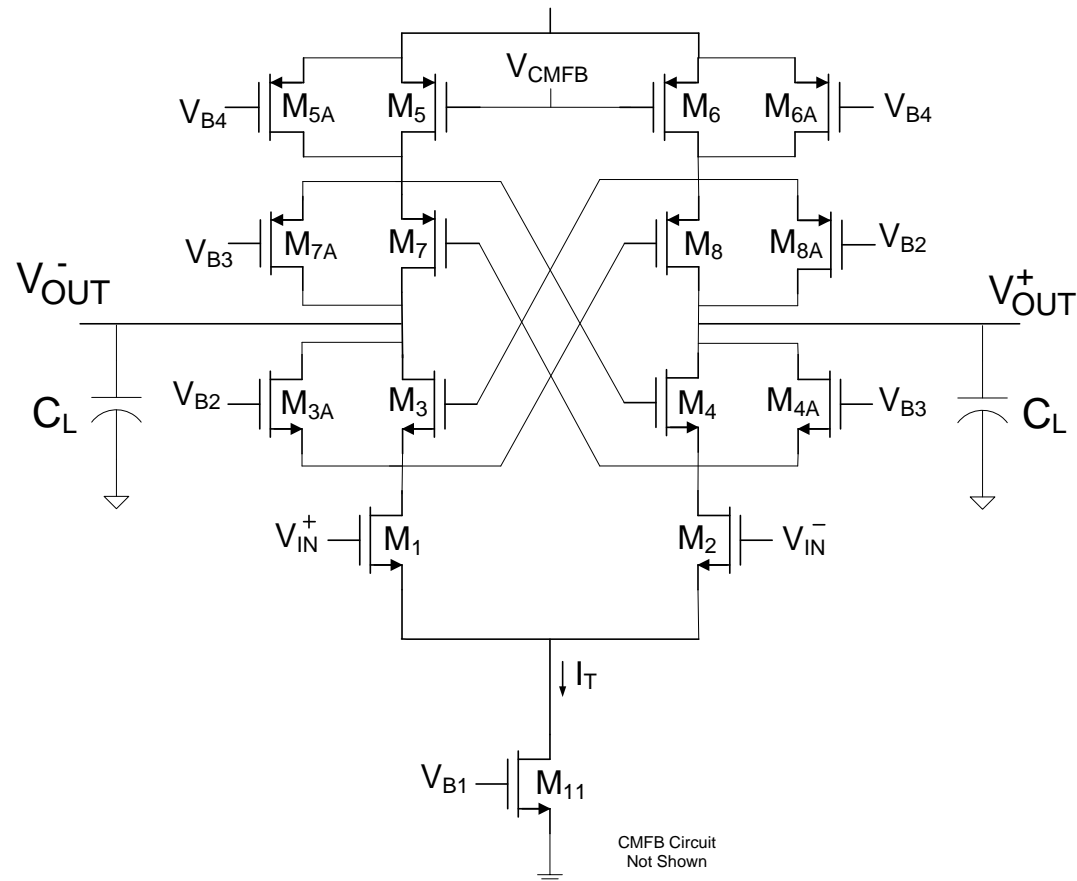

- Regenerative feedback can be to either quarter circuit or counterpart circuit
- Regenerative feedback to cascode devices can significantly reduce the magnitude of the negative conductance term

Another Positive Feedback Amplifier

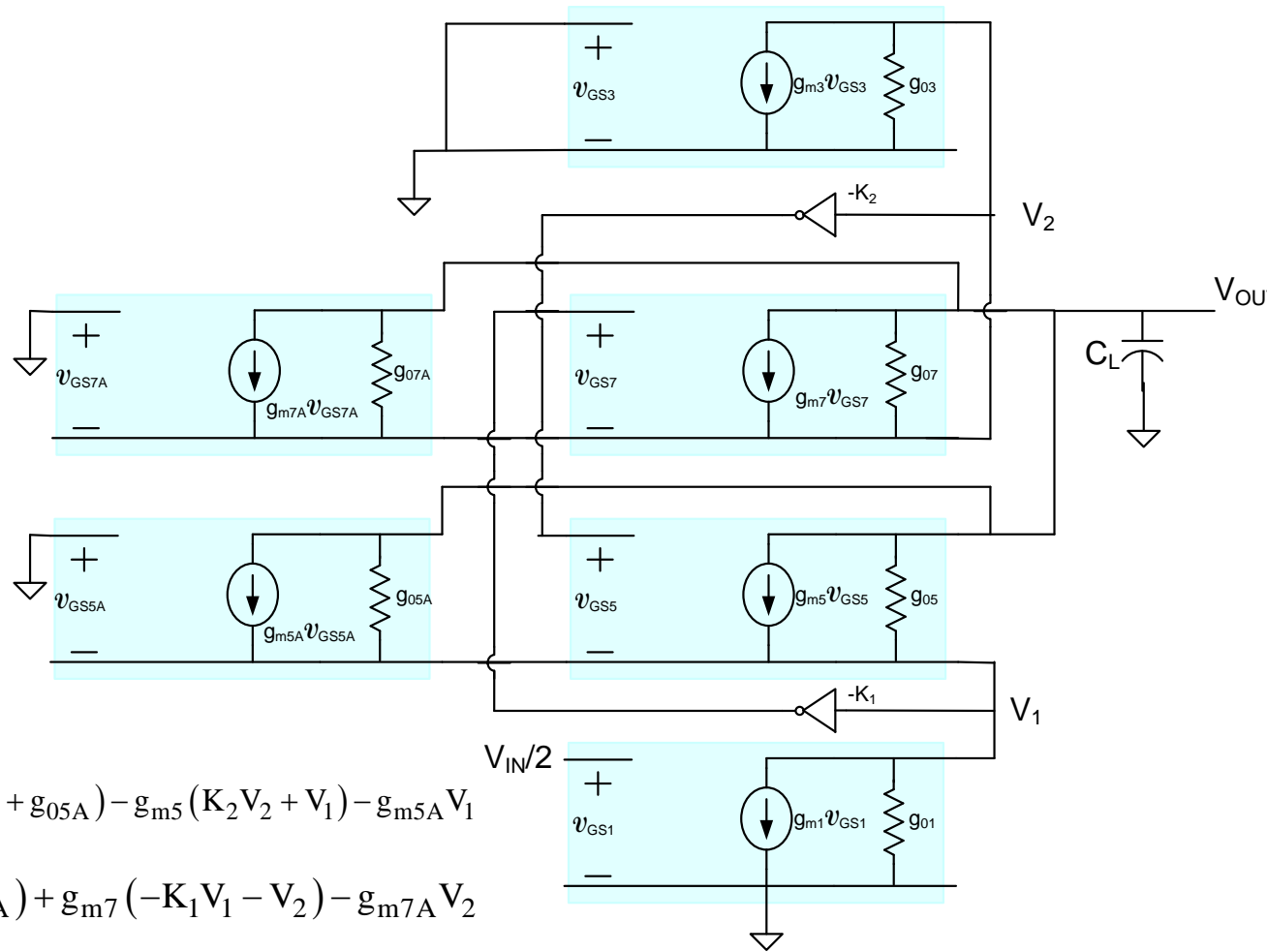
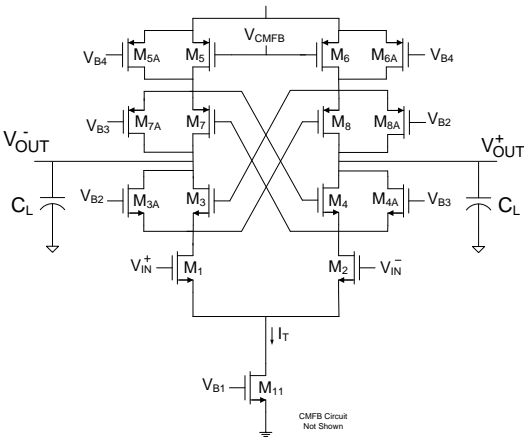

Small-signal half circuit

$$V_1 (g_{01} + g_{05} + g_{05A}) + g_{m1} V_{IN} / 2 = V_0 (g_{05} + g_{05A}) - g_{m5} (K_2 V_2 + V_1) - g_{m5A} V_1$$

$$V_2 (g_{03} + g_{07} + g_{07A}) = V_0 (g_{07} + g_{07A}) + g_{m7} (-K_1 V_1 - V_2) - g_{m7A} V_2$$

$$V_0 (sC_L + g_{05} + g_{05A} + g_{07} + g_{07A}) = V_2 (g_{07} + g_{07A}) + V_1 (g_{05} + g_{05A}) + g_{m7} (K_1 V_1 + V_2) + g_{m7A} V_2 + g_{m5} (K_2 V_2 + V_1) + g_{m5A} V_1$$

Ki=0 if cross-coupling absent, 1 if cross-coupling present

Another Positive Feedback Amplifier

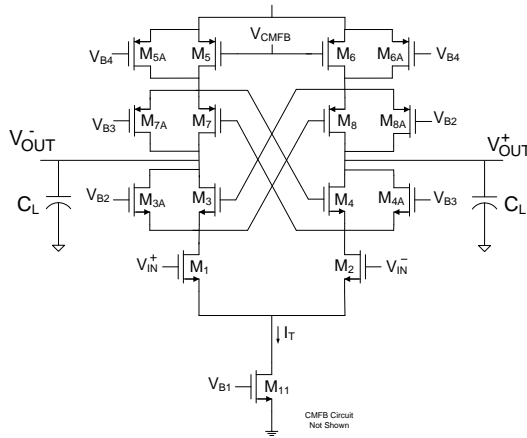

$$V_1(g_{01} + g_{05} + g_{05A}) + g_{m1}V_{IN}/2 = V_0(g_{05} + g_{05A}) - g_{m5}(K_2V_2 + V_1) - g_{m5A}V_1$$

$$V_2(g_{03} + g_{07} + g_{07A}) = V_0(g_{07} + g_{07A}) + g_{m7}(-K_1V_1 - V_2) - g_{m7A}V_2$$

$$V_0(sC_L + g_{05} + g_{05A} + g_{07} + g_{07A}) = V_2(g_{07} + g_{07A}) + V_1(g_{05} + g_{05A}) + g_{m7}(K_1V_1 + V_2) + g_{m7A}V_2 + g_{m5}(K_2V_2 + V_1) + g_{m5A}V_1$$

Transfer function solution with MAPLE $T(s)=N(s)/S(s)$

$$\begin{aligned} \text{num} := & -(-K_1 K_2 g_{m5} g_{m7} + g_{m5} g_{m7} + g_{m7A} g_{m5} + g_{07} g_{m5} + g_{03} g_{m5} \\ & + g_{07A} g_{m5} + K_1 g_{03} g_{m7} + g_{m5A} g_{m7} + g_{05} g_{m7} + g_{05A} g_{m7} \\ & + g_{05A} g_{07A} + g_{05} g_{07A} + g_{05A} g_{m7A} + g_{05} g_{m7A} + g_{05} g_{07} \\ & + g_{05} g_{03} + g_{m5A} g_{m7A} + g_{05A} g_{07} + g_{m5A} g_{03} + g_{05A} g_{03} \\ & + g_{m5A} g_{07A} + g_{m5A} g_{07}) g_{m1} \end{aligned}$$

$$\begin{aligned} \text{den} := & -g_{01} g_{07} g_{m5} K_2 - g_{m7} K_1 g_{05A} g_{03} - g_{m7} K_1 g_{05} g_{03} \\ & - g_{01} g_{07A} g_{m5} K_2 + (g_{m5A} g_{m7A} + g_{m7A} g_{m5} + g_{05A} g_{03} \\ & + g_{05A} g_{m7A} + g_{m5} g_{m7} + g_{01} g_{m7} + g_{05} g_{m7} + g_{05A} g_{m7} \\ & + g_{m5A} g_{m7} - K_1 K_2 g_{m5} g_{m7} + g_{01} g_{07} + g_{m5A} g_{03} + g_{05} g_{m7A} \\ & + g_{03} g_{m5} + g_{05} g_{03} + g_{05} g_{07A} + g_{05} g_{07} + g_{01} g_{07A} \\ & + g_{05A} g_{07} + g_{m5A} g_{07A} + g_{05A} g_{07A} + g_{07} g_{m5} + g_{m5A} g_{07} \\ & + g_{07A} g_{m5} + g_{01} g_{03} + g_{01} g_{m7A}) sC_L + g_{m7} g_{05} g_{01} \\ & + g_{05A} g_{01} g_{03} + g_{m7} g_{05A} g_{01} + g_{m5A} g_{07A} g_{03} + g_{m5A} g_{07} g_{03} \\ & + g_{05A} g_{07} g_{03} + g_{05} g_{07} g_{03} + g_{m5} g_{07} g_{03} + g_{01} g_{07A} g_{03} \\ & + g_{01} g_{07} g_{03} + g_{05A} g_{01} g_{07A} + g_{05A} g_{01} g_{07} + g_{05} g_{01} g_{03} \\ & + g_{05A} g_{01} g_{m7A} + g_{05} g_{01} g_{07} + g_{05} g_{01} g_{m7A} + g_{05} g_{07A} g_{03} \\ & + g_{05} g_{01} g_{07A} + g_{m5} g_{07A} g_{03} + g_{05A} g_{07A} g_{03} \end{aligned}$$

Ki=0 if cross-coupling absent, 1 if cross-coupling present

Another Positive Feedback Amplifier

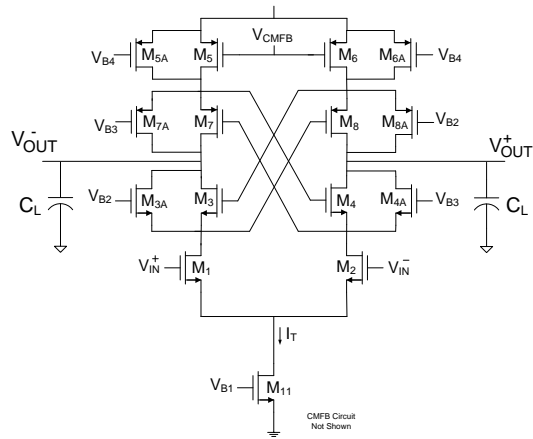

$$V_1(g_{01} + g_{05} + g_{05A}) + g_{m1} V_{IN} / 2 = V_0(g_{05} + g_{05A}) - g_{m5}(K_2 V_2 + V_1) - g_{m5A} V_1$$

$$V_2(g_{03} + g_{07} + g_{07A}) = V_0(g_{07} + g_{07A}) + g_{m7}(-K_1 V_1 - V_2) - g_{m7A} V_2$$

$$V_0(sC_L + g_{05} + g_{05A} + g_{07} + g_{07A}) = V_2(g_{07} + g_{07A}) + V_1(g_{05} + g_{05A}) + g_{m7}(K_1 V_1 + V_2) + g_{m7A} V_2 + g_{m5}(K_2 V_2 + V_1) + g_{m5A} V_1$$

$$T(s) = N(s)/D(s)$$

Neglecting g_o terms compared to g_m terms, simplifies to:

$$\text{num} := (g_{m5h} g_{m7h} - K_1 K_2 g_{m5} g_{m7} + K_1 g_{o3} g_{m7} + g_{m5h} g_{o3} + g_{o7h} g_{m5h} + g_{o5h} g_{m7h}) g_{m1}$$

$$\begin{aligned} \text{den} := & (K_1 K_2 g_{m5} g_{m7} - g_{m5h} g_{m7h} - g_{o7h} g_{m5h} - g_{o1} g_{m7h} - g_{o5h} g_{m7h} \\ & - g_{m5h} g_{o3}) sC_L - g_{o7h} g_{o1} g_{o5h} - g_{o7h} g_{o1} g_{o3} - g_{o7h} g_{o5h} g_{o3} \\ & - g_{o1} g_{o5h} g_{m7h} - g_{o1} g_{o5h} g_{o3} - g_{o7h} g_{m5h} g_{o3} \\ & + g_{o5h} g_{m7} K_1 g_{o3} + g_{o7h} g_{o1} g_{m5} K_2 \end{aligned}$$

Practical Comments about Positive Feedback Gain Enhancement

- Significant gain enhancement is possible but most designers avoid regenerative feedback because of unfounded concerns about closed-loop stability
- Accuracy and settling time can be improved with some regenerative feedback
- Will become more critical in emerging processes where g_m/g_o ratios degrade and where supply voltages shrink thus limiting the longstanding cascode process
- Regenerative structures can have high sensitivities
- Signal swing quite limited in some of the most basic regenerative feedback structures
- Most useful in two-stage architecture where regenerative feedback is used in first stage (effects of signal swing are reduced by gain of second stage)

Summary of Methods of Gain Enhancement

Increasing the output impedance of the amplifier

cascode, folded cascode, regulated cascode, positive feedback

Increasing the transconductance

(current mirror op amp) but it didn't really help because the output conductance increased proportionally

Driving the counterpart circuit does offer some improvements in gain

Cascading gives a multiplicative gain effect

(thousands of architectures but compensation is essential)

usually limited to a two-level cascade because of too much

phase accumulation

One or more of these effects can be combined

Operational Amplifier Architectures

Most of the popular operational amplifier architectures have been introduced

Large number of different architectural choices exist with substantially different performance potential

Choice of architecture is important but judicious use of DOF is essential to obtain good performance

Few architectures offer a GB power efficiency that is better than that of the reference op amp (but some two-stage amplifiers do)

Some variants of the basic amplifier structures such as buffered output stages are commonly used in some applications

Observations about Op Amp Design

- Considerably different insight can often be obtained by viewing a circuit in multiple ways
- Various systematic procedures for designing op amps have been introduced
- It is important to understand the design space and to identify a good set of design variables
 - design spaces can be explored in many different ways but the degrees of freedom are incredibly valuable resources and should be used judiciously
- Cascaded amplifiers offer potential for gain enhancement but compensation schemes to practically work with more than two levels of cascading have not yet emerged
- Positive feedback appears to provide a promising approach for building high gain amplifiers in low voltage processes but research is ongoing into how this concept can be fully utilized



Stay Safe and Stay Healthy !

End of Lecture 19